



Metal Hoods FMN, Right Angled Cable Outlet

Metallhauben FMN, rechtwinkliger Kabelausgang



Metal hood FMN in shell sizes 5.
Metallhaube FMN in der Gehäusegröße 5.

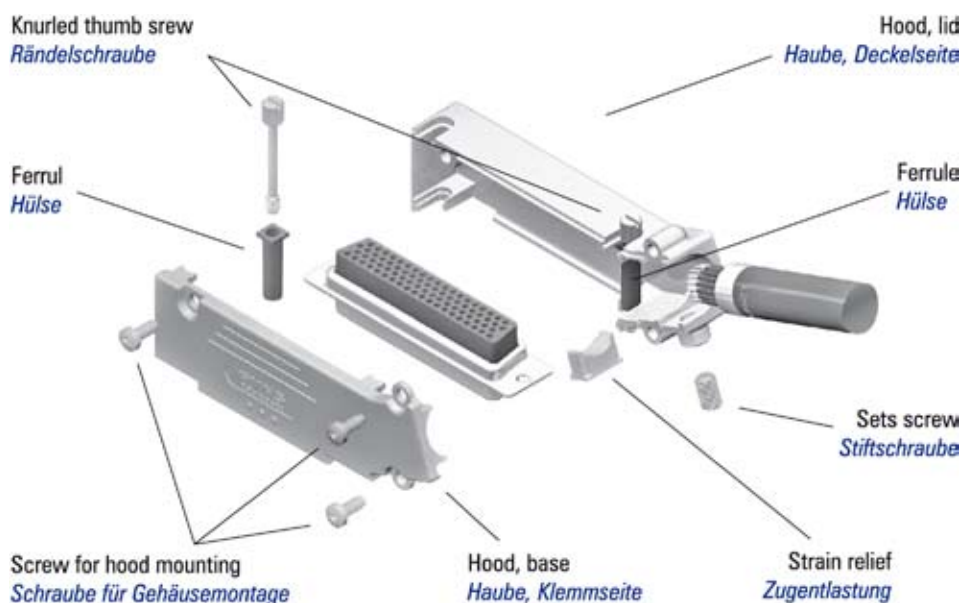

Special Features of the Hood Series

Besondere Merkmale der Haubenserie

- Particularly low version for cramped conditions
- 90° cable outlet with strain relief
- Suitable for robust use
- Can be used with knurled thumb screws
- Premounted knurled thumb screws
- With insert in two dimensions for cable strain relief

- *besonders niedrige Version für begrenzte Einbauhöhe*
- *90° Kabelausgang mit Zugentlastung*
- *für robuste Einsätze geeignet*
- *verwendbar mit Rändelschrauben*
- *vormontierte Rändelschrauben*
- *mit Einlegeteil in zwei Größen zur Zugentlastung des Kabels*

Packing Units

Verpackungseinheiten

Please see page 108
siehe Seite 108



Metal Hoods FMN, Right Angled Cable Outlet

Metallhauben FMN, rechtwinkliger Kabelausgang

Dimensions

Abmessungen

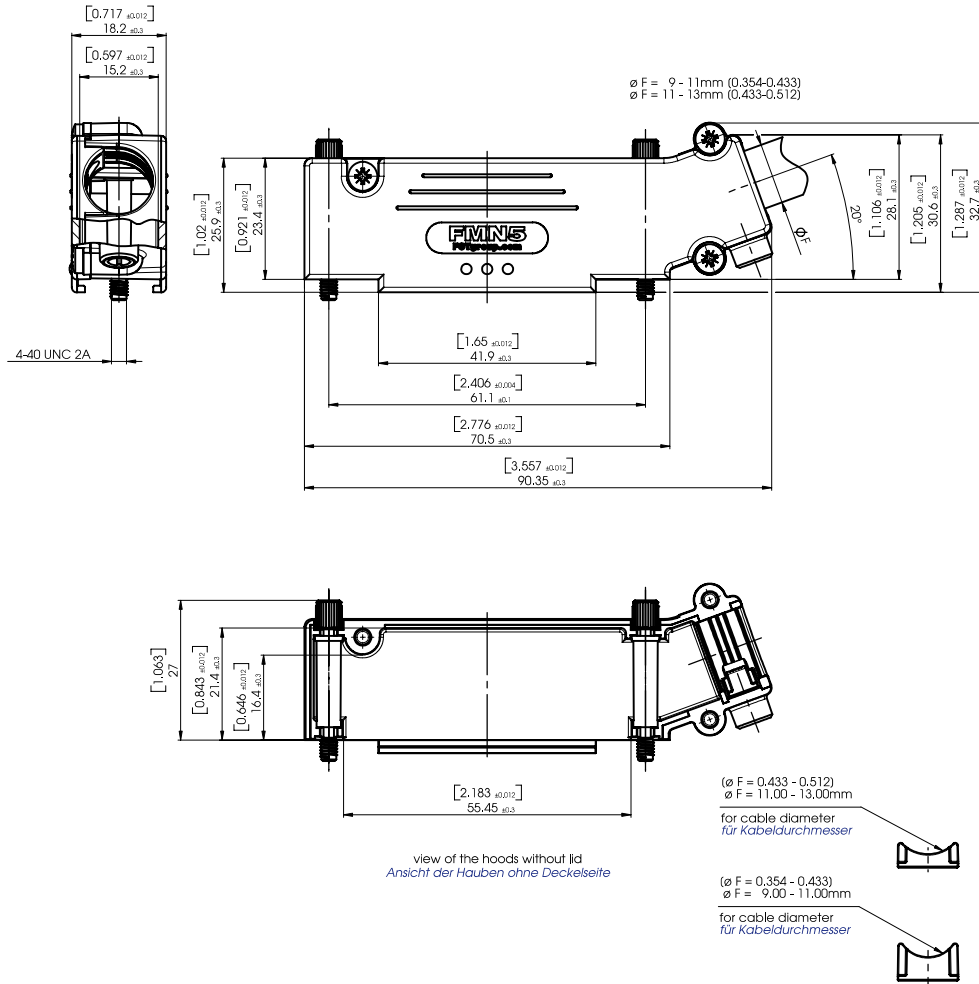

Application Example

Einsatzbeispiel

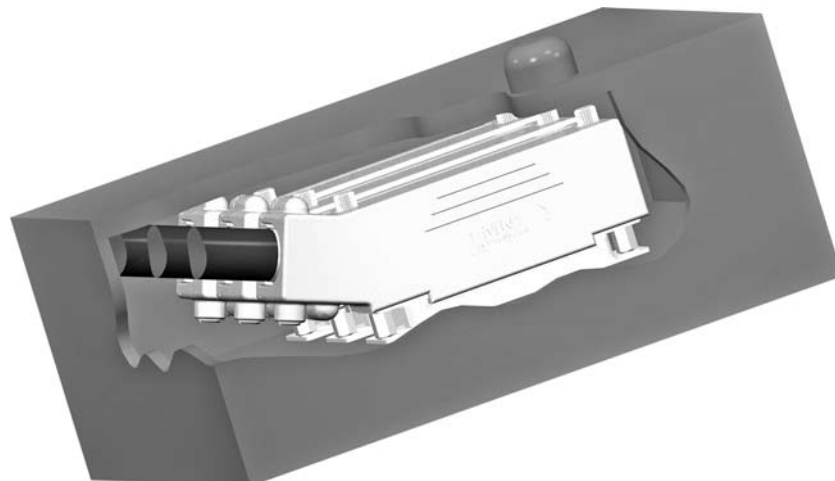



Metal Hoods FMN, Right Angled Cable Outlet

Metallhauben FMN, rechtwinkliger Kabelausgang

Mounting Instructions

Montagehinweise

Step 1 / *Schritt 1:*

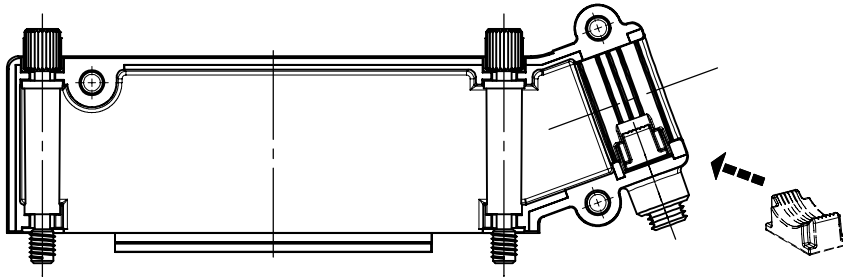

Step 2 / *Schritt 2:*

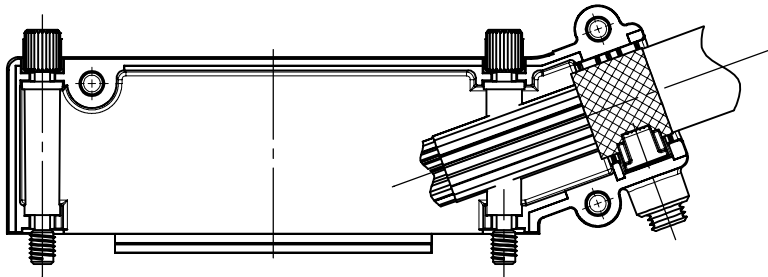

Step 3 / *Schritt 3:*

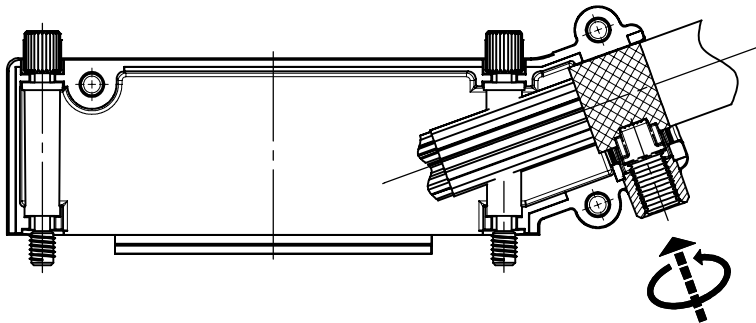

Step 4 / *Schritt 4:*

